

2021

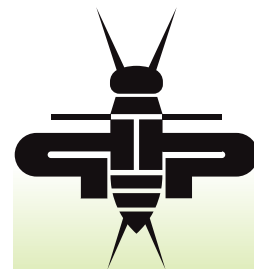

Grillo

AGRIGARDEN
MACHINES



G Z1 - G Z2









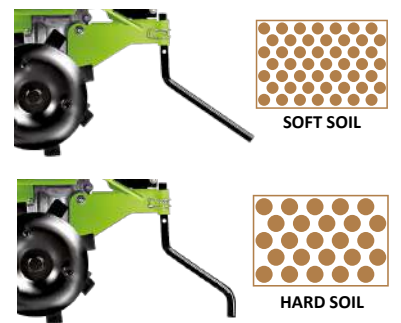
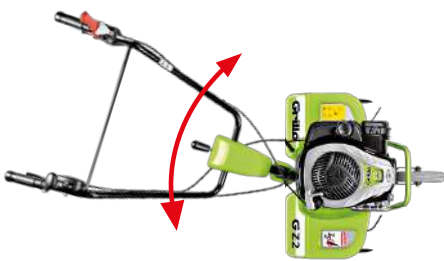





G Z1











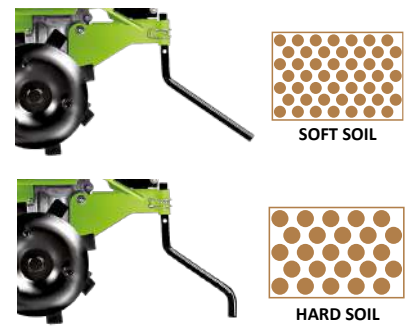



G Z2



										
G Z1	575 EX B&S	HP 3 - kW 2.2	140/1	0,8 (0.84)		155 rpm	--	A 28 cm (11 in)	52 cm (20 in)	35 (77)
G Z2	575 EX B&S	HP 3 - kW 2.2	140/1	0,8 (0.84)		155 rpm	Max 2,1 km/h (1.3 mph)	A 28 cm (11 in)	52 cm (20 in)	41 (90)

G Z3



										
	HP-kW	CC	L (US qts)							kg (lb)
G Z3	GCV 170 Honda	HP 4.8 - kW 3.6	166/1	0,9 (0.95)		155 rpm	Max 2,1 km/h (1.3 mph)	A 28 cm (11 in)	75 cm (29.5 in)	45 (99)



PRINCESS MR

PRINCESS







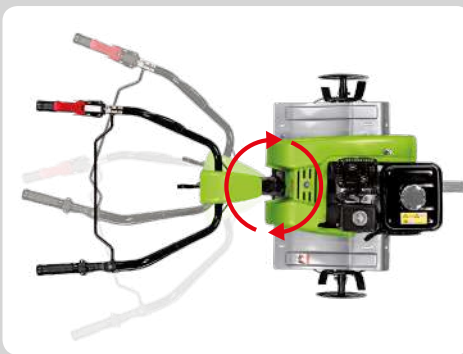



M1 - MR



PRINCESS M1



PRINCESS MR

		HP-kW	CC	 L (US qts)						 kg (lb)
M1	3000 Serie Kohler	HP 5.5 - kW 4.1	196/1	3,6 (3.8)		① 132 rpm	--	A 32 cm (12 in)	30-52-77 cm (12-20-30 in)	62 (137)
MR	3000 Serie Kohler	HP 5.5 - kW 4.1	196/1	3,6 (3.8)		① 132 rpm	Max 2,3 km/h (1.4 mph)	A 32 cm (12 in)	30-52-77 cm (12-20-30 in)	64 (141)
	GX 200 Honda	HP 5.5 - kW 4.1	196/1	3,1 (3.3)						62 (137)



PRINCESS

MP3









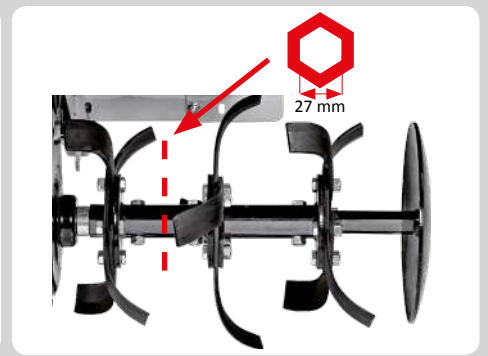



		HP-kW	CC	L (US qts)				A		kg (lb)
MP3	3000 Serie Kohler	HP 5.5 - kW 4.1	196/1	3,6 (3.8)		① 36 rpm ② 160 rpm	Max 2,3 km/h (1.4 mph)	A 32 cm (12 in)	30-52-77 cm (12-20-30 in)	65 (143)











PRINCESS MP3 PRO



										
MP3 PRO	GX 200 Honda	HP 5.5 - kW 4.1	196/1	3,1 (3.3)		<ul style="list-style-type: none"> ⓘ 36 rpm Ⓜ 160 rpm 	Max 2,3 km/h (1.4 mph)	A 33 cm (13 in)	56-82 cm (22-32 in)	66 (145)

3500



										
3500	3000 Serie Kohler	HP 5.5 - kW 4.1	196/1	3,6 (3.8)		I 53 rpm II 123 rpm	Max 3 km/h (1.8 mph)	A 32 cm (12 in)	58-85-111 cm (23-33-43 in)	81 (179)
	GX 200 Honda	HP 5.5 - kW 4.1	196/1	3,1 (3.3)		79 (174)				

11500

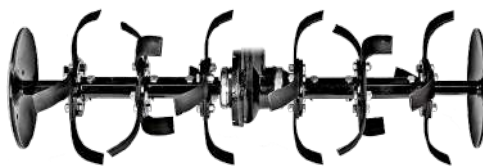
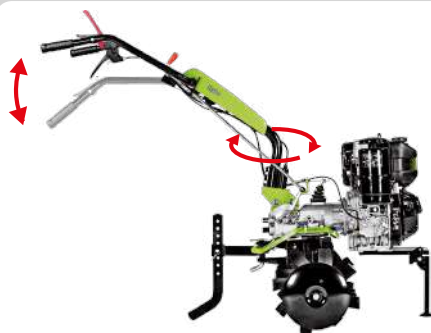







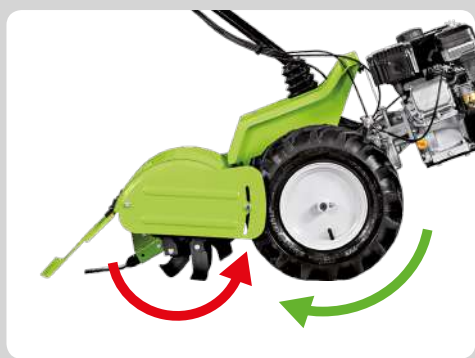





		HP-kW	CC	 L (US qts)						 kg (lb)
11500	G300FA Loncin	HP 9.3 - kW 6.8	302/1	6,1 (6.4)		① 53 rpm ② 123 rpm ③ 162 rpm	Max 3 km/h (1.8 mph)	A 33 cm (13 in)	59-86-112 cm (23-34-44 in)	92 (203)
	GX 270 Honda	HP 8.4 - kW 6.3	265/1	5,3 (5.6)						92 (203)
	KD15 350 Kohler	HP 7.5 - kW 5.5	349/1	Diesel 4,3 (4.5)						110 (242)
										121 (267)

G 45

CONTRA-ROTATING TILLER



















										
G 45	G200FA Loncin	HP 5.5 - kW 4.1	196/1	3 (3.2)		 4.00-8 1,6 km/h (1 mph) →	 4.00-8 2,5 km/h (1.5 mph) ←	A 26 cm (10 in)	50 cm (20 in)	82 (181)

G 46















CONTRA-ROTATING TILLER



										
G 46	GX 200 Honda	HP 5.5 - kW 4.1	196/1	3,1 (3.3)		 4.00-8 1,6 km/h (1 mph) →	 4.00-8 1,6 km/h (1 mph) ←	 A 26 cm (10 in)	 50 cm (20 in)	 98 (216)

G 52





















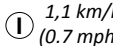

											
G 52	G200FA Loncin	HP 5.5 - kW 4.1	196/1	3 (3.2)			 13x5.00-6 1,4 km/h (0.9 mph) → 2,2 km/h (1.4 mph) ←	 13x5.00-6 2,2 km/h (1.4 mph) → 1,4 km/h (0.9 mph) ←	A 26 cm (10 in)	37-50 cm (15-20 in)	67 (148)

G 55

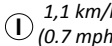

LABOUR KIT

















		HP-kW	CC	 L (US qts)						 kg (lb)
G 55	3000 Serie Kohler	HP 5.5 - kW 4.1	196/1	3,6 (3.8)		 4.00-8	 4.00-8	A 26 cm (10 in)	37-50-58 cm (15-20-23 in)	86 (189)
	GX 200 Honda	HP 5.5 - kW 4.1	196/1	3,1 (3.3)		 4.00-8  1,1 km/h (0.7 mph)  2,6 km/h (1.6 mph)  1,1 km/h (0.7 mph)  2,6 km/h (1.6 mph)	 4.00-8  1,1 km/h (0.7 mph)  2,6 km/h (1.6 mph)  1,1 km/h (0.7 mph)  2,6 km/h (1.6 mph)			87 (192)

G 84



FORWARD AND CONTRA-ROTATING TILLER



		HP-kw	 CC	 L (US qts)						 kg (lb)
G 84	GX 200 Honda	HP 5.5 - kW 4.1	196/1	3,1 (3.3)		 4.00-8 ① 1,1 km/h (0.7 mph) ② 2,6 km/h (1.6 mph) →	 4.00-8 ① 1,1 km/h (0.7 mph) ② 2,6 km/h (1.6 mph) →	A 32 cm (12 in)	37-47-58 cm (15-19-23 in)	111 (245)
						 4.00-8 ① 1,1 km/h (0.7 mph) ② 2,6 km/h (1.6 mph) ←	 4.00-8 ① 1,1 km/h (0.7 mph) ② 2,6 km/h (1.6 mph) ←			

G 85d



FORWARD AND CONTRA-ROTATING TILLER



		HP-kW	CC	 L (US qts)		 DIFF. LOCK					 kg (lb)
G 85d	G300FA Loncin	HP 9.3 - kW 6.8	302/1	6,1 (6.4)		✓	4.00-10	4.00-10			127 (280)
	R300D Rato	HP 8.2 - kW 6	301/1	5,4 (5.7)		✓	⓪ 1,3 km/h (0.8 mph) Ⓜ 3,0 km/h (1.9 mph)	⓪ 1,3 km/h (0.8 mph) Ⓜ 3,0 km/h (1.9 mph)	A 32 cm (12 in)	37-47-58-68- 77 cm (15-19-23-27- 30 in)	142 (313)
	KD 15 350 Kohler	HP 7.5 - kW 5.5	349/1	Diesel 4,3 (4.5)		✓	➔ 1,3 km/h (0.8 mph) Ⓜ 3,0 km/h (1.9 mph)	➔ 1,3 km/h (0.8 mph) Ⓜ 3,0 km/h (1.9 mph)			132 (291)
							⓪ 1,3 km/h (0.8 mph) Ⓜ 3,0 km/h (1.9 mph)	⓪ 1,3 km/h (0.8 mph) Ⓜ 3,0 km/h (1.9 mph)			151 (332)

G 107d



		HP-kW	CC	 L (US qts)		 DIFF. LOCK						 kg (lb)
G 107d	G300FA Loncin	HP 9.3 - kW 6.8	302/1	 6,1 (6.4)		✓	 5.00-10	 5.00-10				136 (300)
	KD 15 440 Kohler	HP 11 - kW 8.1	441/1	Diesel 5 (5.3)		✓	 ① 1,3 km/h (0.8 mph) ② 2,4 km/h (1.5 mph) ③ 3,6 km/h (2.2 mph)	 ① 1,3 km/h (0.8 mph) ② 2,4 km/h (1.5 mph) ③ 3,6 km/h (2.2 mph)				154 (339)
	R300D Rato	HP 8.2 - kW 6	301/1	 5,4 (5.7)		✓	 ① 1,3 km/h (0.8 mph) ② 2,4 km/h (1.5 mph) ③ 3,6 km/h (2.2 mph)	 ① 1,3 km/h (0.8 mph) ② 2,4 km/h (1.5 mph) ③ 3,6 km/h (2.2 mph)				150 (330)
	KD 15 440 Kohler	HP 11 - kW 8.1	441/1	Diesel 5 (5.3)		✓	 ① 1,3 km/h (0.8 mph) ② 2,4 km/h (1.5 mph) ③ 3,6 km/h (2.2 mph)	 ① 1,3 km/h (0.8 mph) ② 2,4 km/h (1.5 mph) ③ 3,6 km/h (2.2 mph)				168 (370)

G 108 - G 110

































G 108



G 110



		 CC/HP HP-kW	 DIESEL L (US qts)		 Steering Brakes	 DIFF. LOCK				 kg (lb)
G 108	GX 270 Honda	270 cc/1 HP 8.4 - kW 6.3	 5,3 (5.6)		✓	✓	 5.00-10	 5.00-10		136 (300)
G 110	GX 390 Honda	389 cc/1 HP 11.7 - kW 8.7	 6,1 (6.4)		✓	✓	 1,3 km/h (0.8 mph)  2,4 km/h (1.5 mph)  4,3 km/h (2.7 mph)	 1,3 km/h (0.8 mph)  2,4 km/h (1.5 mph)  4,3 km/h (2.7 mph)	A 32 cm (12.6 in)	37-47-58-68- 77 cm (15-19-23-27- 30 in)
	KD 15 440 Kohler	441 cc/1 HP 11 - kW 8.1	 Diesel 5 (5.3)		✓	✓	 0,7 km/h (0.4 mph)  1,5 km/h (0.9 mph)  3,2 km/h (2.0 mph)	 0,7 km/h (0.4 mph)  1,5 km/h (0.9 mph)  3,2 km/h (2.0 mph)		168 (370)

G 131 BC



		HP-kW	CC	 L (US qts)		 DIFF. LOCK				 kg (lb)	
G 131 BC	Vanguard 16 B&S	HP 14 (16*) kW 10.3	479/2	8,5 (8.9)		✓	 5.00-12 ① 1,2 km/h (0.7 mph) ② 2,4 km/h (1.5 mph) ③ 3,4 km/h (2.1 mph) ④ 7.1 km/h (4.4 mph) ① 1,7 km/h (1.0 mph) ② 3,5 km/h (2.2 mph)	 5.00-12 ① 1,7 km/h (1.0 mph) ② 3,5 km/h (2.2 mph)	A 32 cm (12.6 in)	55-70-85 cm (22-28-34 in)	195 (430)

* Gross Power

























DUMPER 406



									
Dumper 406	3000 Serie Kohler	HP 5.5 - kW 4.1	196/1			① 1,0 km/h (0.6 mph) ② 2,0 km/h (1.2 mph) ③ 3,5 km/h (2.2 mph)	① 1,0 km/h (0.6 mph) ② 2,0 km/h (1.2 mph) ③ 3,5 km/h (2.2 mph)	400 kg (882 lb)	267 (589)
	GX 200 Honda	HP 5.5 - kW 4.1	196/1						268 (591)











DUMPER 507



									
Dumper 507	GX 270 Honda	HP 8.4 - kW 6.3	270/1	 5,3 (5.6)		 1,0 km/h (0.6 mph)  2,0 km/h (1.2 mph)  3,5 km/h (2.2 mph)  8,7 km/h (5.4 mph)	 1,0 km/h (0.6 mph)  2,0 km/h (1.2 mph)  3,5 km/h (2.2 mph)	500 kg (1102 lb)	310 (683)
	R300D Rato	HP 8.2 - kW 6	301/1	 5,4 (5.7)					319 (703)
	KD15 350 Kohler	HP 7.5 - kW 5.5	349/1	Diesel  4,3 (4.5)					312 (688)
	KD15 350 Kohler	HP 7.5 - kW 5.5	349/1	Diesel  4,3 (4.5)					337 (743)









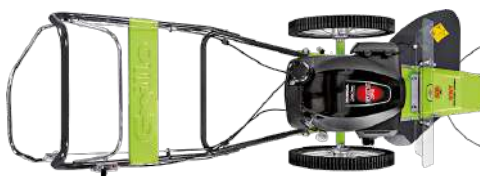

HWT 550 Tilt



										
HWT 550 Tilt	GCV170 Honda	HP4.8 - kW3.6	166/1	0,9 (1)		--	41 cm (16.2 in)	15-30-50-60 mm (0.6-1.2-2-2.4 in)	60 cm (24 in)	42 (93)

HWT 600 WD









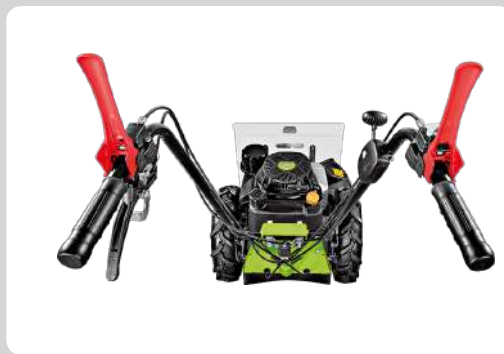



										
HWT 600 WD	GCV 170 Honda	HP 4.8 - kW 3.6	166/1	0,9 (1)		2,5 km/h (1.5 mph)	41 cm (16.2 in)	15-30-50-60 mm (0.6-1.2-2-2.4 in)	60 cm (24 in)	47 (104)

HWT 700









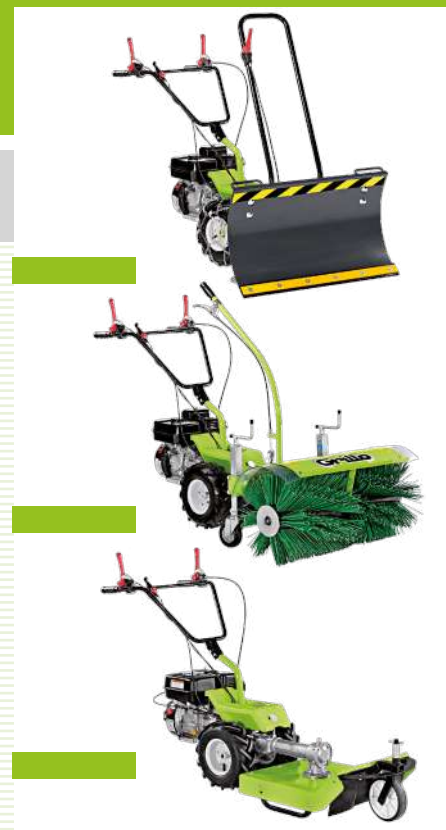

SUPERTRAC



											
		HP-kW	CC	L (US qts)						kg (lb)	
HWT 700 SUPERTRAC	<i>Kawasaki</i> FJ180V KAI	HP 4.5 - kW 3.4	179/1	1.7 (1.5)		2,5 km/h (1.5 mph)	3.50-8	38 cm (14.9 in)	15-30-50-60 mm (0.6-1.2-2-2.4 in)	60 cm (24 in)	62 (137)













GF 1



										
GF 1	G200FA Loncin	HP 5.5 - kW 4.1	196/1	3 (3.2) L (US qts)		13x5.00-6	2,20 km/h (1.4 mph)	-	86-96 cm (34-38 in)	70 (154) kg (lb)

GF 2





































										
	3000 Serie Kohler	HP 5.5 - kW 4.1	196/1	3,6 (3.8)			4.00-8	4.00-8	110-115-117 cm (43-45-46 in)	95 (209)
GF 2	GX 200 Honda	HP 5.5 - kW 4.1	196/1	3,1 (3.3)			① 1,0 km/h (0.6 mph) ② 2,0 km/h (1.2 mph) ③ 3,0 km/h (1.9 mph)	① 1,0 km/h (0.6 mph) ② 2,0 km/h (1.2 mph) ③ 3,0 km/h (1.9 mph)		96 (212)

GF 3 - GF 3DF



GF 3DF



		HP-kW	CC 	 L (US qts)		 Steering Brakes	 DIFF. LOCK				 kg (lb)
GF 3	G300FA Loncin	HP 9.3 - kW 6.8	302/1	 6,1 (6.4)		-	-	 4.00-8	 4.00-8		110 (242)
	GX 270 Honda	HP 8.4 - kW 6.3	270/1	 5.3 (5.6)		-	-				110 (242)
	KD 15 350 Kohler	HP 7.5 - kW 5.5	349/1	 4,3 (4.5)				 I 1,0 km/h (0.6 mph)	 I 1,0 km/h (0.6 mph)	110-115-117 127-135 cm (43-45-46-50- 53 in)	120 (264)
GF 3DF	G300FA Loncin	HP 9.3 - kW 6.8	302/1	 6,1 (6.4)				 II 2,0 km/h (1.2 mph)	 II 2,0 km/h (1.2 mph)		117 (258)
	GX 270 Honda	HP 8.4 - kW 6.3	270/1	 5.3 (5.6)				 III 3,0 km/h (1.9 mph)	 III 3,0 km/h (1.9 mph)		117 (258)
	KD 15 350 Kohler	HP 7.5 - kW 5.5	349/1	 4,3 (4.5)							127 (280)











GH 7 - GH 9



		HP-kW	CC	 L (US qts)						 kg (lb)		
GH 7	GX 200 Honda	HP 5.5- kW 4.1	196/1	3,1 (3.3)		HYDROSTATIC		0 - 6 km/h (0 - 3.7 mph)	0 - 3 km/h (0 - 1.9 mph)	30...110 mm (1.2...4.3 in)	68 cm (26.8 in)	148 (326)
GH 9	GX 270 Honda	HP 8.4- kW 6.3	270/1	5,3 (5.6)		HYDROSTATIC		0 - 6 km/h (0 - 3.7 mph)	0 - 3 km/h (0 - 1.9 mph)	30...110 mm (1.2...4.3 in)	68 cm (26.8 in) 85 cm (33.5 in)	158 (348) 165 (364)









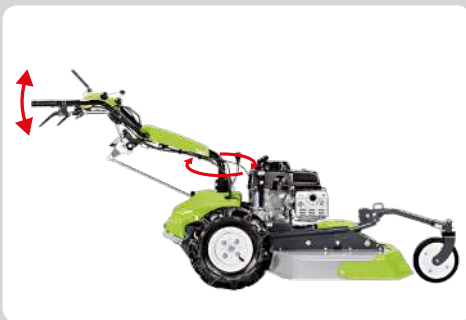

CL 62M



		HP-kW		 L (US qts)						 kg (lb)		
CL 62M	FJ180V Kawasaki	HP 4.5 - kW 3.4	179/1	1,6 (1.5)		HYDROSTATIC		0 - 4,7 km/h (0 - 2.9 mph)	0 - 3 km/h (0 - 1.9 mph)	50...110 mm (2.0...4.3 in)	62 cm (24.4 in)	98 (216)

CL 75



		HP-kW		 L (US qts)							
							HYDROSTATIC				
CL 75	GXV 390 Honda	HP 10.2 - kW 7.6	389/1	2,1 (2.2)		✓	0 - 6 km/h (0 - 3.7 mph)	0 - 3,5 km/h (0 - 2.2 mph)	50...150 mm (2.0...5.9 in)	75 cm (29.5 in)	140 (309)

CLIMBER 7

7.15 - 7.18





















CLIMBER 7.18



CLIMBER 7.18



		HP-kW		 L (US qts)	 DIFF. LOCK					 kg (lb)
7.15	LC1P92F Loncin	HP 12(*15) kW 9.2	452/1	 7 (7.4)		HYDROSTATIC 0 - 9 km/h (0 - 5.6 mph)	 45 cm (18 in)	 35...85 mm (1.3...3.3 in)	 85 cm (33.5 in)	250 (551)
7.18	INTEK 7180 B&S	HP 15.2 - kW 11.2	656/2	 7 (7.4)		HYDROSTATIC 0 - 9 km/h (0 - 5.6 mph)	 45 cm (18 in)	 35...85 mm (1.3...3.3 in)	 85 cm (33.5 in)	255 (562)











CLIMBER 8

8.22



KIT MULCHING



		HP-kW		 L (US qts)						
8.22	7220 Prof. Series B&S	HP18-kW13.2	656/2	 7 (7.4)	 ✓	HYDROSTATIC 0 - 10 km/h (0 - 6.2 mph)	60 cm (23.6 in)	35...110 mm (1.3...4.3 in)	91 cm (36 in)	290 (639)

CLIMBER 9

9.18 - 9.22



CLIMBER 9.18











CLIMBER 9.22



CLIMBER 9.18











KIT MULCHING

		HP-kW		 L (US qts)						
9.18	INTEK 7180 B&S	HP15.2-kW11.2	656/2	13 (13.7)	✓	HYDROSTATIC 0 - 10 km/h (0 - 6.2 mph)	38 cm (15 in)	30...90 mm (1.2...3.5 in)	91 cm (36 in)	297 (655)
9.22	7220 Prof. Series B&S	HP18-kW13.2	656/2	13 (13.7)	✓	HYDROSTATIC 0 - 10 km/h (0 - 6.2 mph)	38 cm (15 in)	30...90 mm (1.2...3.5 in)	91 cm (36 in)	311 (686)

CLIMBER 9

9.27













		HP-kW		 L (US qts)	 DIFF. LOCK	 HYDROSTATIC			 kg (lb)	
9.27	8270 Commercial Series B&S	HP 22 - kW 16.2	724/2	13 (13.7)	✓	0 - 11,5 km/h (0 - 7.1 mph)	70 cm (27.5 in)	35...135 mm (1.4...5.3 in)	98 cm (38 in)	358 (789)

CLIMBER 10

AWD 22













		HP-kW		 L (US qts)	 DIFF. LOCK	 HYDROSTATIC				 kg (lb)
AWD 22	7220 Prof. Series B&S	HP18-kW13.2	656/2	 13 (13.7)		0 - 9 km/h (0 - 5.6 mph)	70 cm (27.5 in)	35...135 mm (1.4...5.3 in)	93 cm (36.6 in)	345 (761)

CLIMBER 10

AWD 27



		HP-kW		 L (US qts)	 DIFF. LOCK	 HYDROSTATIC			 kg (lb)	
AWD 27	8270 Commercial Series B&S	HP 22 - kW 16.2	724/2			0 - 9 km/h (0 - 5.6 mph)	70 cm (27.5 in)	35...135 mm (1.4...5.3 in)	98 cm (38.6 in)	385 (849)

MD 15-MD 18



MD 18













MD 18



MD 15









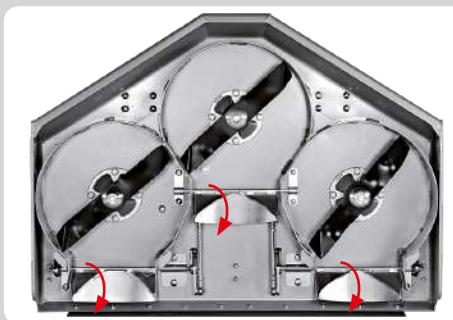

MD 18

		HP-kW		 L (US qts)	 DIFF. LOCK					 kg (lb)
MD 15	LC1P92F Loncin	HP 12(*15) kW 9.2	452/1	 7 (7.4)	—	HYDROSTATIC 0 - 9 km/h (0 - 5.6 mph)	45 cm (18 in)	25...75 mm (1.0...3.3 in)	QUICK SHIFT 83 cm (32.6 in)	225 (496)
MD 18	INTEK 7180 B&S	HP 15.2 - kW 11.2	656/2	 7 (7.4)	✓	HYDROSTATIC 0 - 9 km/h (0 - 5.6 mph)	45 cm (18 in)	25...80 mm (1.0...3.5 in)	QUICK SHIFT 83 cm (32.6 in)	238 (525)

MD 22N



		HP-kW		 L (US qts)						
					DIFF. LOCK	HYDROSTATIC			QUICK SHIFT	kg (lb)
MD 22N	7220 Prof. Series B&S	HP 18-kW13.2	656/2	7 (7.4)	✓	0 - 10,5 km/h (0 - 6,5 mph)	48 cm (18.9 in)	25...110 mm (0.9...4.3 in)	110 cm (43 in)	315 (694)

MD 24 AWD

MD 28 AWD



MD 28 AWD















MD 24 AWD



MD 28 AWD













		HP-kW		 L (US qts)						
MD 24 AWD	7220 Prof. Series B&S	HP18 - kW13.2	656/2	 13 (11.8)		HYDROSTATIC 0 - 9 km/h (0 - 5,6 mph)	70 cm (27.5 in)	25...110 mm (0.9...4.3 in)	QUICK SHIFT 110 cm (43 in)	370 (816)
MD 28 AWD	8270 Commercial Series B&S	HP22 - kW16.2	724/2	 13 (11.8)		0 - 9 km/h (0 - 5,6 mph)	70 cm (27.5 in)	25...110 mm (0.9...4.3 in)	130 cm (51 in)	383 (844)

FX 27











Zero-Turn



										
FX 27	8270 Commercial Series B&S	HP22 - kW 16.2	724/2	 30 (7.9) L (US Gal)	0 - 12 km/h (0 - 7.4 mph) HYDROSTATIC	ZERO TURN	30...85 mm (1.2...3.3 in) ELECTRIC	125 cm (49 in)	484 (1067)	H 170 cm D 132 cm W 258 cm













FD 220R



		HP-kW		 L (US qts)						
FD 220R	LC1P92F Loncin	HP 12(*15) kW 9.2	452/1	 7 (7.4)	HYDROSTATIC 0 - 9 km/h (0 - 5.6 mph)	200 L 5.7 (US bu)	30 cm (11.8 in)	30...90 mm (1.2...3.5 in)	80 cm (31 in)	263 (580)
	VANGUARD 16 B&S	HP 14 - kW 10.3	479/2	 7 (7.4)	HYDROSTATIC 0 - 9 km/h (0 - 5.6 mph)	200 L 5.7 (US bu)	30 cm (11.8 in)	30...90 mm (1.2...3.5 in)	80 cm (31 in)	270 (595)
										H 114 cm D 86 cm W 234 cm















FD 280



		HP-kW		 L (US qts)								
FD 280	VANGUARD 16 B&S	HP 14 - kW10.3	479/2			HYDROSTATIC 0-9,5 km/h (0-5.9 mph)	ELECTRIC 280 L 8 (US bu)	30 cm (11.8 in)	30...90 mm (1.2...3.5 in)	113 cm (44 in)	320 (705)	H 120 cm D 119 cm W 238 cm

FD 450



												
	HP-kW	CC	L (US Gal)	DIFF. LOCK		HYDROSTATIC	HYDRAULIC	HYDRAULIC	ELECTRIC		kg (lb)	
FD 450	7220 Prof. Series B&S	HP 18 - kW 13.2	656/2			0 - 11 km/h (0 - 6.8 mph)	450 L 12.8 (US bu)	30 cm (11.8 in)	25...90 mm (1.0...3.5 in)	113 cm (44 in)	450 (992)	H 194 cm D 119 cm W 268 cm

FD 900

4WD

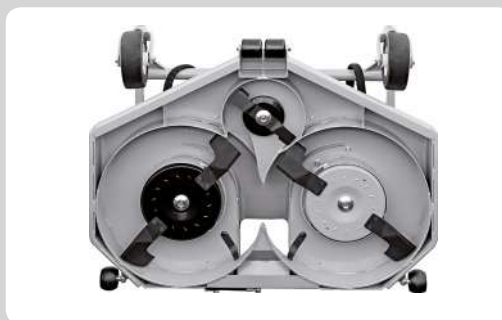

		HP-kW	CC	 L (US Gal)	 DIFF. LOCK	 HYDROSTATIC	 HYDRAULIC	 HYDRAULIC	 HYDRAULIC	 HYDRAULIC	 kg (lb)	 H D W
FD 900 4WD	3TNV80F Yanmar	HP 25 - kW 18.4	1267/3	Diesel 31 (8.2)	✓	0 - 15 km/h (0 - 9 mph)	750 L 21.3 (US bu)	37 cm (14.6 in)	20...100 mm (0.8...3.9 in)	126 cm (49.6 in)	980 (2160)	H 166 cm D 133 cm W 291 cm

FD 13.09

4WD



		HP-kW	CC	L (US Gal)	DIFF. LOCK	HYDROSTATIC	HYDRAULIC	HYDRAULIC	HYDRAULIC	HYDRAULIC	kg (lb)		
FD 13.09 4WD	3TNV82A Yanmar	HP 26 - kW 18.9	1331/3	Diesel 23 (6.0)	✓	0 - 15 km/h (0 - 9.3 mph)	900 L 25.5 (US bu)	31 cm (12 in)	HYDRAULIC	20...100 mm (0.8...3.9 in)	132 cm (52 in)	1230 (2712)	H 175 cm D 141 cm W 325 cm
									HYDRAULIC	20...120 mm (0.8...4.7 in)	155 cm (61 in)	1310 (2888)	H 175 cm D 162 cm W 340 cm

FD 2200

4WD



		HP-kW		 L (US Gal)	 DIFF. LOCK	 HYDROSTATIC	 HYDRAULIC	 HYDRAULIC			 kg (lb)	 H D W
FD 2200 4WD	3TNV88C Yanmar	HP 37 kW 27.5	1642/3	Diesel 50 (13.2)	✓	0 - 20 km/h (0 - 12.4 mph)	1200 L 34 (US bu)	62 cm (24 in)	25...110 mm (0.9...4.3 in)	155 cm (61 in)	1468 (3236)	H 183 cm D 162 cm W 347 cm

FD 2200 TS

4WD



		HP-kW		L (US Gal)	DIFF. LOCK	HYDROSTATIC	HYDRAULIC	HYDRAULIC	HYDRAULIC	HYDRAULIC	kg (lb)	
FD 2200 TOP SCORER 4WD	4TNV88C Yanmar	HP 47 kW 34.3	2190/4	Diesel 50 (13.2)	✓	0 - 21 km/h (0 - 13.6 mph)	1400 L 39.7 (US bu)	60 cm (24 in)	20...120 mm (0.8...4.7 in)	155 cm (61 in)	1656 (3651)	H 199 cm D 162 cm W 364 cm
										180 cm (71 in)		1705 (3758)

FM 13.09

4WD



		HP-kW		 L (US Gal)	 DIFF. LOCK	 HYDROSTATIC		 HYDRAULIC			 kg (lb)	
FM 13.09 4WD	3TNV82A Yanmar	HP26 - kW18.9	1331/3	Diesel 23 (6.0)	✓	0 - 15 km/h (0 - 9.3 mph)	12000 m ² /h	31 cm (12 in)	20...100 mm (0.8...3.9 in)	160 cm (63 in)	1150 (2535)	H 175 cm D 192 cm W 325 cm

FM 2200

4WD



		HP-kW	CC	L (US Gal)	DIFF. LOCK	HYDROSTATIC	15500 m ² /h	HYDRAULIC				
FM 2200 4WD	3TNV88C Yanmar	HP 37 kW 27.5	1642/3	Diesel 50 (13.2)	✓	0 - 20 km/h (0 - 12.4 mph)	15500 m ² /h	62 cm (24 in)	20...90 mm (0.8...3.5 in)	160 cm (63 in)	1322 (2914)	H 185 cm D 192 cm W 342 cm



Nell'ottica di un costante sviluppo dei propri prodotti, Grillo Spa si riserva il diritto di cambiare le specifiche tecniche e le illustrazioni su questo documento in qualsiasi momento e senza preavviso né obbligo. Foto e caratteristiche non contrattuali. In the pursuit of constant development of his products, Grillo Spa reserves for himself the right to change the technical specifications and the illustrations on this document, at any given moment and without notice and without any kind of obligation. All the pictures characteristics are not contract-binding. En poursuivant une politique constante d'amélioration de ses produits, Grillo Spa se réserve le droit de modifier les spécifications techniques en tout temps sans préavis ni obligation. Photographies et caractéristiques non contractuelles. Aufgrund ständiger Weiterentwicklung behält sich Grillo Spa Änderungen in Form, Technik und Ausstattung der Produktpalette vor. Aus Angaben und Abbildungen des vorliegenden Grillo-Katalogs können daher keine Ansprüche abgeleitet werden. En vista de un desarrollo constante de sus productos, Grillo Spa se reserva el derecho de cambiar las especificaciones técnicas y las ilustraciones mostradas en este documento en cualquier momento y sin aviso previo. Las fotos y características no son contractuales.



www.grillospa.it
 e-mail: grillo@grillospa.it
 Tel. (0039) 0547.633111
 Fax (0039) 0547.632011

www.grillofrance.fr
www.grilloagrigarden.co.uk
www.grillodeutschland.de
www.grilloagrigarden.ru